

Step 1 - Prepare the Mast

Practice
this technique on scrap tubing
as necessary.

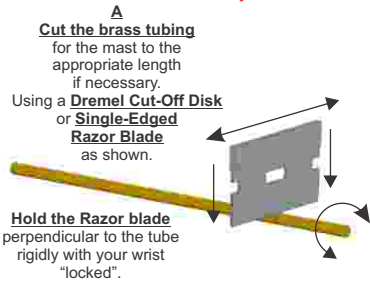

While pressing down
with **light pressure** to begin with,
roll the tubing with the razor blade
back and forth on a **hard surface**.

After a few rolls,
the tubing should snap off cleanly.

The end of the tubing
may need to be opened using a #78 drill bit.

Optional:
See **Step 4** for details

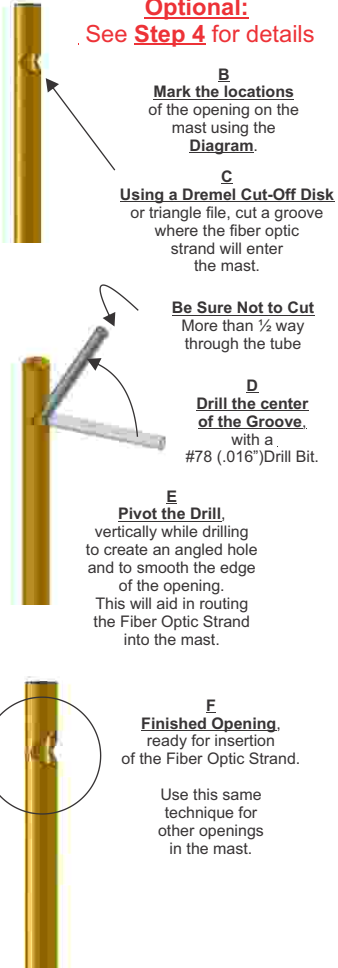

Step 2 - Assemble the Parts

Tools You May Need:

1/32" Drill Bit
#78 Drill Bit
Needle Files
Single Edge Razor Blade
Dremel Tool

We recommend you use
Duro brand Super Glue
to assemble the parts.

Clean and Deburr all Parts
before beginning assembly. Some parts
may need to be opened with
a 1/32" drill bit.

Before Applying Glue
Test fit all parts by sliding them
in place in their correct order n the mast.

Mark the locations
of the parts on the mast using
the N Scale **Diagram** provided.

Painting
We suggest painting
the completed
assembly before
installing the
Fiber Optic Strand

See the Painting/Finishing
Information on Page 2

Prepare the Signal Head for the Fiber Optic Strand



Drill through
the pilot hole in the signal head with a
#78 (.016") drill.

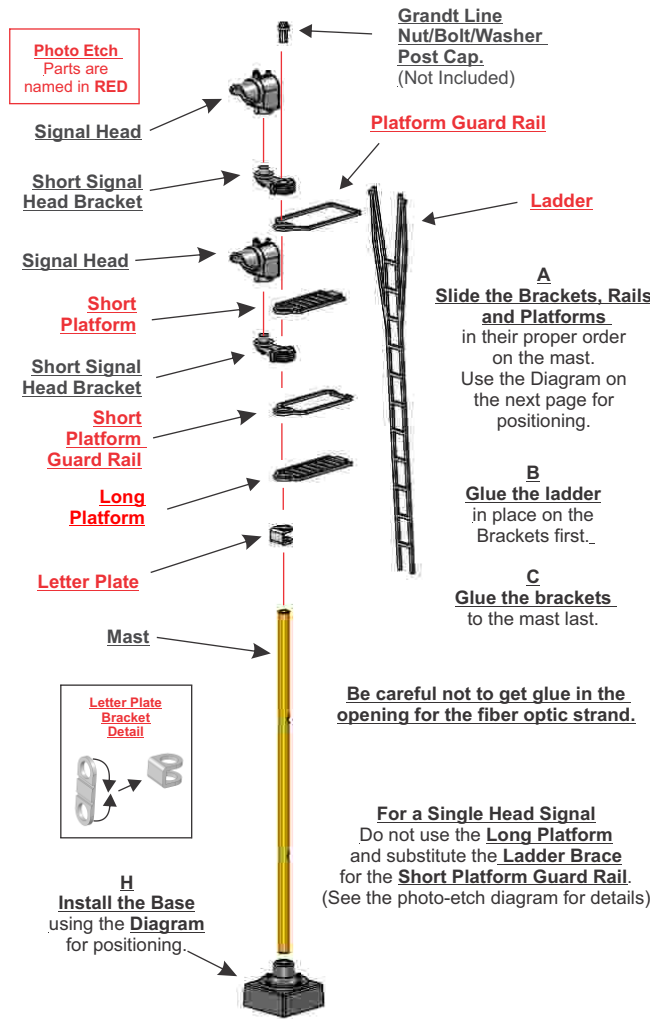

For a Single Head Signal
Do not use the **Long Platform**
and substitute the **Ladder Brace**
for the **Short Platform Guard Rail**.
(See the photo-etch diagram for details)

Add the Details

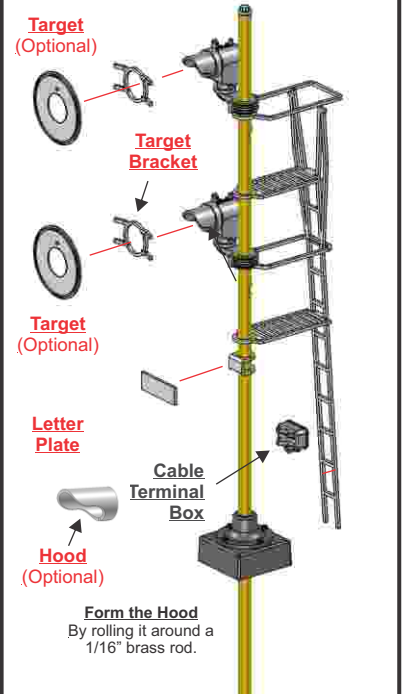

Step 3 - Insert the FO Strand

The Following Steps are for a lighted signal.

Flare the end of the Fiber Optic Strand by holding it close to - but not touching - a heat source such as a soldering iron tip. This will enhance the output of the light source and hold the strand in place while it is glued in the signal head.

Place small drop of Kristal Klear or white glue on the strand behind the flared end.

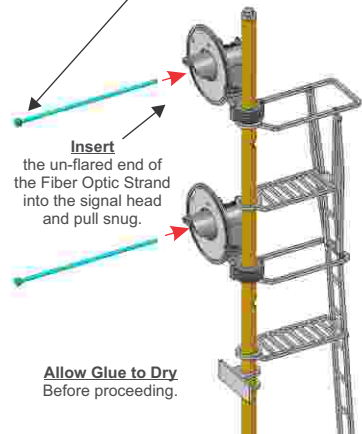
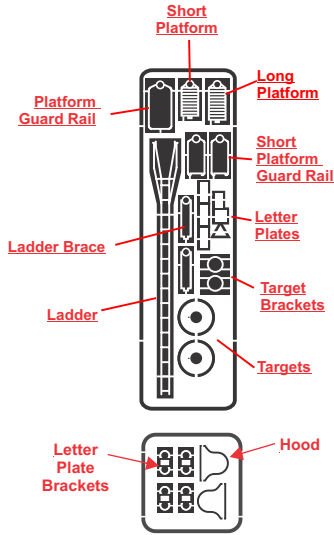

Photo-Etch Details



Remove Parts from the phot-etch fret by cutting through the tags holding the parts in place with a heavy knife blade on a hard surface.

Painting / Finishing

Painting by Manufacturer:

"Signals and all metal surfaces exposed to the weather shall have shop coat of red lead. Relay houses and instrument cases to have shop coat of red lead and two coats of aluminum paint on outside surface. Inside of houses and instrument cases to have shop coat of red lead between the steel and lining and after lining is installed the interior including all shelves and supports to be painted with aluminum paint."

Painting by Railroad:

"Inside of all signal masts must be swabbed with raw linseed oil and thoroughly set before installing.

All instrument cases and cable terminal boxes must have a spotting coat and a final coat of aluminum paint inside and out.

Signal face and hood to be painted dead black

All other metal surfaces must have spotting of primary paint where required and two coats of aluminum paint."

Letter Plates are to be given two coats of Dead Black paint. Face of letters and back of plate to be painted aluminum.

A History of the Searchlight Signal

In late 1916 the invention of the doublet lens combination for daytime color light signals prompted the management of the Hall Signal Company to realize that even their most advanced Style "L" semaphore mechanism (the very last produced by any U.S. signal company), had been rendered obsolete. That dual lens device had been developed by Cornell University's Dr. William Churchill, while he was working at Corning Glass Works. He had recently finished developing color standards for railroad glassware, which Corning had patented on October 10, 1905. The doublet lens combination was fully patented by 1911.

Hall's response to this situation was to buy the 1918 filed patents from one Mr. Blake for his "Searchlight" signal. In reality, the searchlight signal was an updated and modernized variation of the old Hall enclosed disc signal. What Blake had done was to harness the standard railroad three position polarized vane relay, add a miniature spectacle and roundels, and couple that with a very efficient elliptical reflector and optical lens system. This revolutionary development, provided a signal with a visible indication of over a mile from the signal in broad daylight, when the signal was located on tangent track. The early color light signals were visible for only about half that distance (2,500 feet) while using about the same current consumption, then a major concern in "Primary Battery Territory." By 1925, the development of "High Transmission Colors" of railroad glassware by Churchill and Corning Glass improved this limited distance to an acceptably competitive 3,500 feet on tangent track.

Searchlight signals became popular because of their low maintenance (compared with semaphores), high visibility and low power-consumption, often a 4 watt, 3 volt bulb, that worked well in territory with battery powered signaling. However as time went on and grid supplied electric power became universal the rationale behind the searchlight began to fade. As labor costs rose the maintenance associated with the classic searchlight's moving parts began to outweigh the savings from its compact size and single bulb. By the end of the 1980s the searchlight had lost its position as the most popular signal style in North America.

Searchlight signals are typically mounted with a large circular background, with one or two railroads preferring a small target, such as the New York Central beginning in the late 1950s.

Searchlight Color Indications:

Green - Used to indicate "clear" or proceed.

Yellow - Used to warn the engineer of an impending stop or speed reduction for an occupied "block" ahead. Also used for low-speed movements.

Red - Used to indicate a full stop or other restrictive condition, or used as a "placeholder" light.

Blue - When on a signal doll arm, indicates intervening track between the signal and the track to which the signal applies.

Lunar White - Blue filtered light to eliminate all trace of yellow used to indicate a restricted proceed condition.

Amber - Used in position light systems as an all-purpose high visibility color, greatest fog penetration.

(Plain) White - Plain incandescent white light. Used in dwarf position light signals with frosted lenses.

Individual signal heads may be set to flash a color to create a different signal aspect. Signals in the United States typically flash only one head at a time, while signals in Canada may flash two heads at a time.

Step 4 - Route the FO Strand

Thread the Fiber Optic Strand into the prepared opening in the mast.

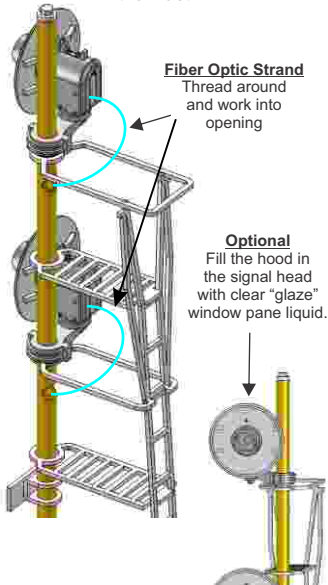

N Scale Diagram

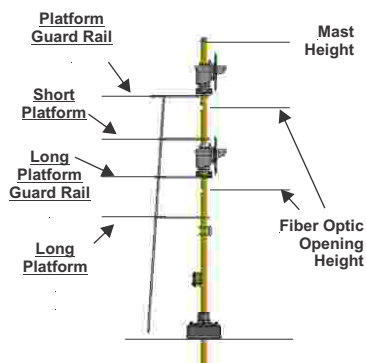

Build Options

