

**PLEASE READ THROUGH THE ENTIRE ASSEMBLY STEPS TO FAMILIARIZE YOURSELF WITH THE PARTS AND METHODS WE RECOMMEND.**

### PARTS

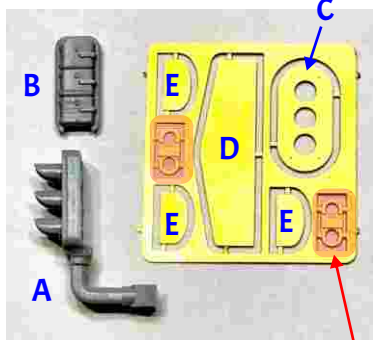

**E**  
**(OPTIONAL)**

**NOT  
USED**

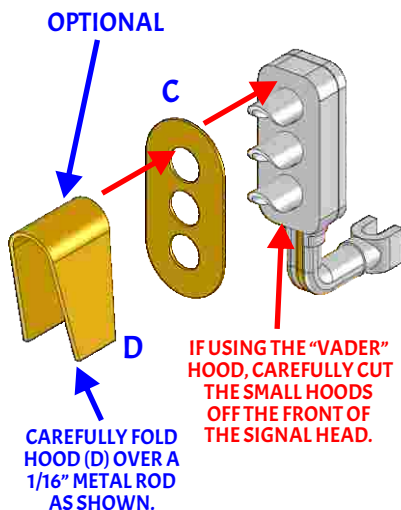
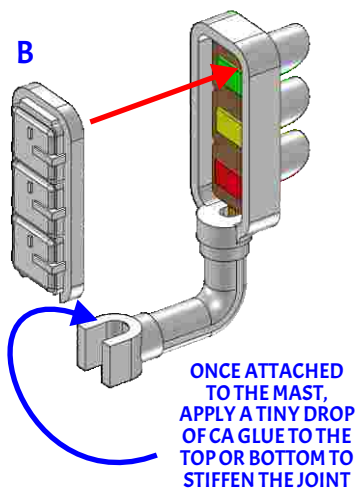
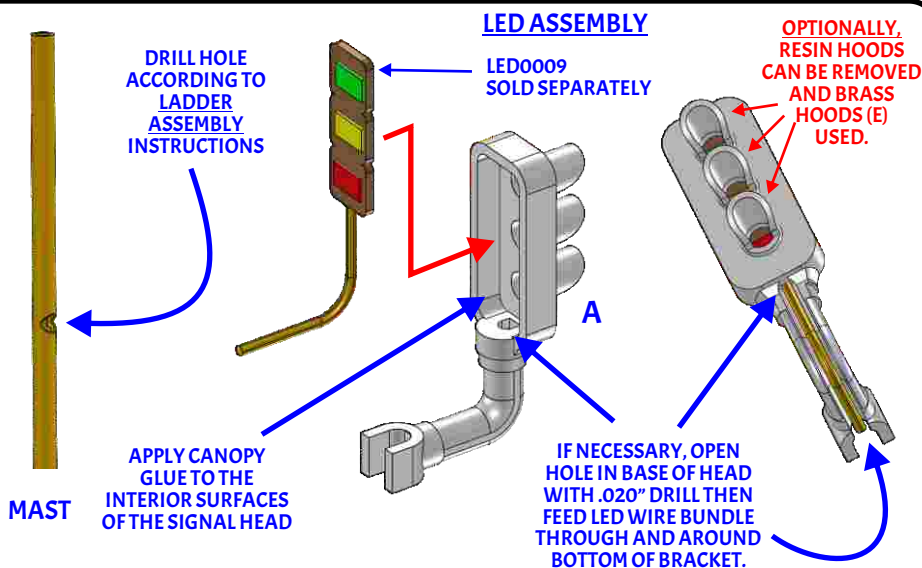

## SIGNAL HEAD ASSEMBLY

- STEP 1** DRILL THROUGH THE SIGNAL MAST (SUPPLIED WITH THE LADDER ASSEMBLY KIT) WITH A .020" DRILL BIT FOR ROUTING THE LED WIRES ACCORDING TO THE INSTRUCTIONS FOR THE LADDER ASSEMBLY.
- STEP 2** APPLY CANOPY GLUE TO THE INSIDE SURFACES OF THE SIGNAL BACK (B) AND THE MOUNTING ELBOW. INSTALL THE LED ASSEMBLY (SOLD SEPARATELY - PRODUCT # LED0009) INTO THE HOUSING ONCE THE CANOPY GLUE HAS DRIED.
- STEP 3** CAREFULLY ROUTE THE LED WIRES THROUGH THE PREVIOUSLY DRILLED HOLE AND DOWN THE MAST. APPLY CANOPY GLUE TO THE HEAD BRACKET "U" JOINT, ALLOW IT TO DRY AND WHILE PULLING THE WIRES CAREFULLY OUT THE BOTTOM OF THE MAST, PUSH THE HEAD BRACKET IN PLACE.
- A TINY DROP OF CA (SUPER) GLUE APPLIED TO THE TOP OR BOTTOM OF THE JOINT CAN HELP STIFFEN THE ASSEMBLY.**
- STEP 4** ATTACH THE SIGNAL SHIELD TO THE BRACKET ASSEMBLY WITH CANOPY GLUE.

**WE RECOMMEND ASSEMBLING WITH SUPER GLUE UNLESS OTHERWISE NOTED.**

### PAINTING THE SIGNAL HEAD ASSEMBLY

WE SUGGEST THAT YOU BUILD THE SIGNAL HEAD ASSEMBLY COMPLETELY BEFORE PAINTING (EXCEPT FOR THE SIGNAL SHIELD). THE SIGNAL SHIELD (A) SHOULD BE PRIMED AND THEN PAINTED FLAT BLACK BEFORE ATTACHING TO THE SIGNAL BACK (B). WE RECOMMEND USING A LAQUER BASED SPRAY PRIMER (TAMIYA SURFACE PRIMER IS A RECOMMENDED CHOICE). USE A SPRAY SILVER FOR THE FINISH COAT. IF THE FINISH IS TOO SHINY, APPLY A COAT OF DULLCOTE FOR A MORE REALISTIC FINISH.

KRISTAL KLEAR CAN BE USED TO FORM A LENS OVER THE LEDs AND WILL BE TRANSPARENT WHEN DRY.