

WE RECOMMEND THAT YOU READ THROUGH THE ASSEMBLY STEPS AND STUDY THE DIAGRAMS CLOSELY TO FAMILIARIZE YOURSELF WITH OUR SUGGESTED ASSEMBLY METHOD.

PARTS

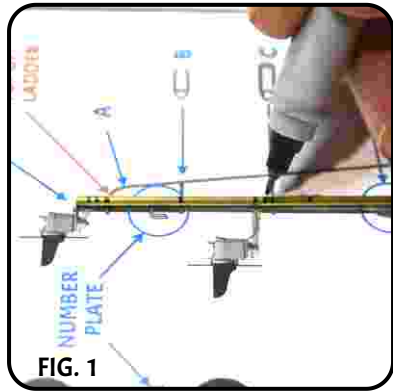
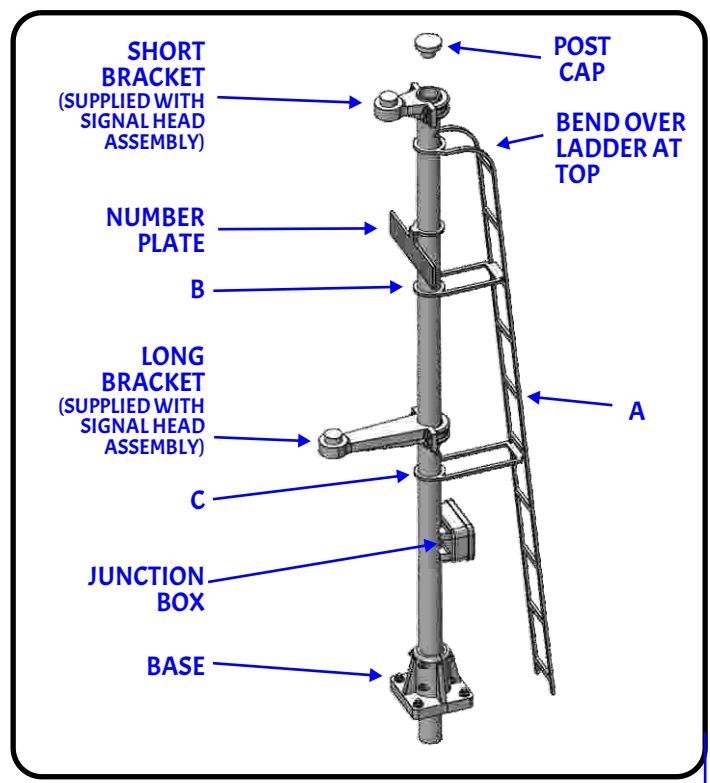
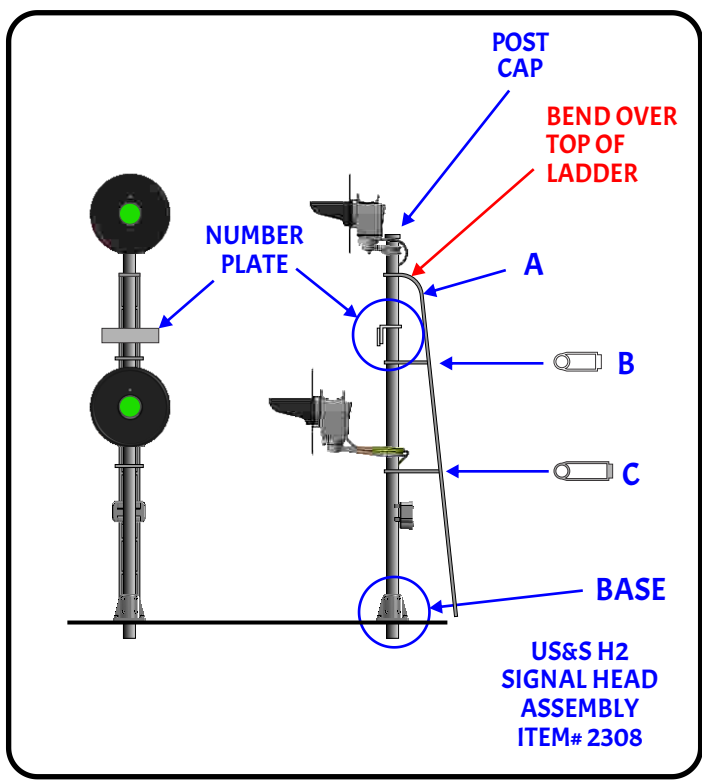
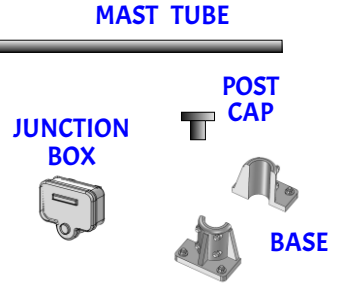

LAY THE BRASS MAST/TUBE DIRECTLY ON THE SUPPLIED DRAWINGS FOR USE AS A TEMPLATE AND MARK THE LOCATIONS OF EACH OF THE ASSEMBLY COMPONENTS (FIG. 1) INCLUDING THE LOCATION(S) FOR THE SIGNAL HEAD AND THE WIRE ENTRY POINT (FIG. 2).

THE DRAWINGS ABOVE ARE IN HO SCALE (1:87) AND CAN BE USED AS A PATTERN FOR MARKING.

THESE ARE ONLY SUGGESTED LOCATIONS SINCE DIFFERENT RAILROAD LINES MAY HAVE DIFFERENT CONFIGURATIONS FOR THE LADDER/MAST ASSEMBLIES.

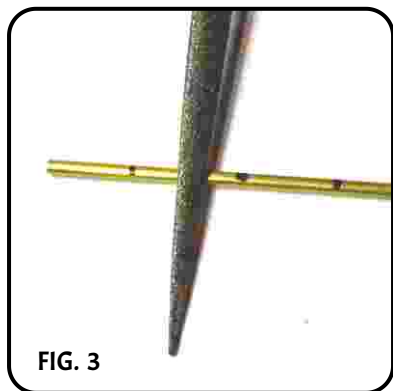
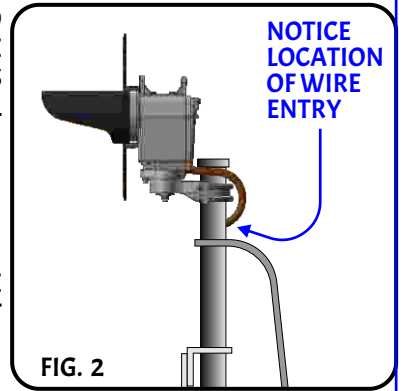

USING THE EDGE OF A DIAMOND NEEDLE FILE, SCRIBE THE LOCATION FOR THE SIGNAL HEAD WIRES TO ENTER THE MAST (FIG. 3). THIS WILL MAKE IT EASIER TO DRILL THROUGH THE ROUND BRASS TUBE.

DRILL THROUGH WITH A 1/32" DRILL BIT.

USE THE DRILL BIT AS A REAMER AND SMOOTH THE INSIDE EDGES OF THE DRILLED HOLE TO HELP PREVENT DAMAGE TO THE INSULATION OF THE WIRE (FIG. 4).

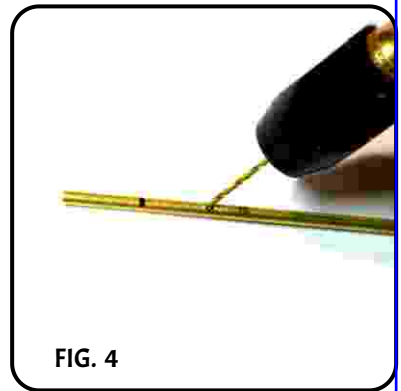

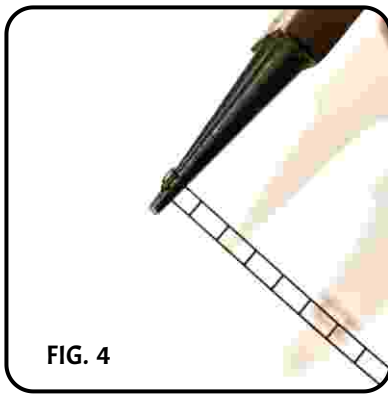

USING NEEDLE NOSE OR ROUND POINT PLIERS, ROUND OVER THE TOP OF THE LADDER (FIG. 4).

USE THE DRAWING AS A GUIDE TO ROUND THE TOP OF THE LADDER OVER.

USE A METAL OR WOOD BLOCK AND A SMALL PIECE OF CLAY TO HOLD THE MAST ABOVE THE WORK SURFACE (FIG. 5).

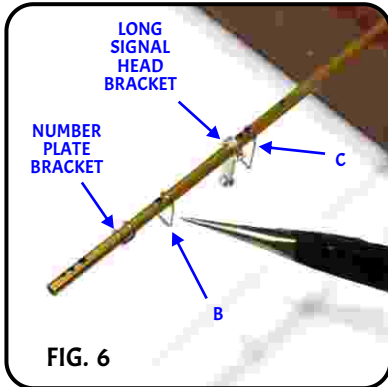
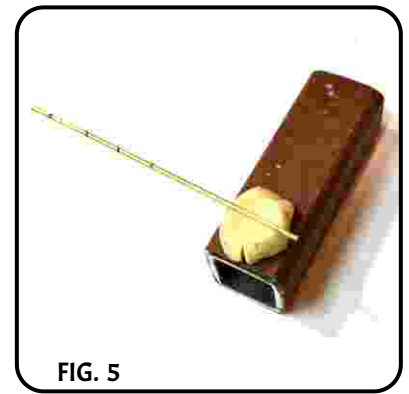

SLIDE EACH LADDER BRACE OF THE MAST ASSEMBLY IN ORDER ACCORDING TO THE DRAWING. (FIG. 6). ALSO SLIDE THE LONG SIGNAL HEAD BRACKET AND NUMBER PLATE BRACKET (FIG. 7) INTO THEIR PROPER PLACES.

NOTE: THESE PARTS MUST CAREFULLY BE POSITIONED IN ORDER BEFORE ANY GLUE IS APPLIED.

ALIGN EACH LADDER BRACKET ON THEIR PREVIOUSLY MARKED POSITIONS ON THE MAST.

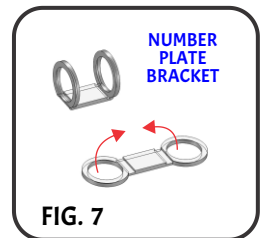

HANGING FROM THE MAST IN POSITION SHOULD ALLOW THEM TO ALIGN SQUARELY.

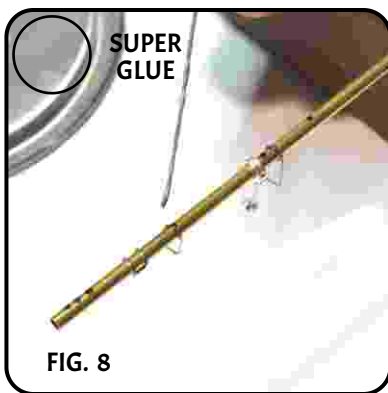

APPLY SEVERAL DROPS OF SUPER GLUE TO A PLASTIC SURFACE FOR A RESERVOIR. WITH EACH LADDER BRACE IN POSITION AND HANGING LOOSELY IN THE VERTICAL POSITION, USE A THIN WIRE TO APPLY A TINY DROP OF SUPER GLUE FROM THE RESERVOIR TO THE MAST AND COMPONENT JOINT ON THE TOP OF THE TUBE (FIG. 8).

DO NOT GLUE THE SIGNAL HEAD BRACKET OR NUMBER PLATE BRACKET YET.

ALLOW THIS TINY GLUE JOINT TO HARDEN.

THE COMPONENTS CAN BE MANIPULATED CAREFULLY ONCE THE GLUE HAS DRIED TO ALLOW YOU TO SQUARE THEM UP.

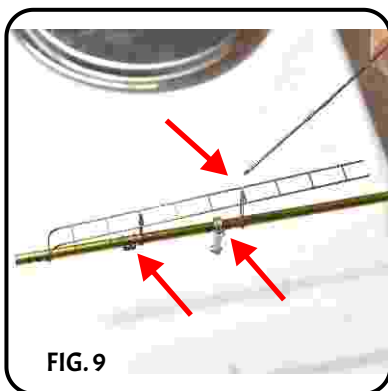

AFTER SQUARING UP THE LADDER PARTS, TURN THE ASSEMBLY OVER SO THE COMPONENTS ARE VERTICAL.

CUT THE LADDER TO LENGTH ACCORDING TO THE DRAWING AND SLIDE IT INTO POSITION ON THE LADDER BRACES. AGAIN USING A TINY DROP OF SUPER GLUE, CAREFULLY TOUCH EACH JOINT AND ALLOW TO DRY (FIG. 9).

MAKE SURE THE LONG HEAD BRACKET IS POSITIONED 180 DEGREES FROM THE LADDER AND TOUCH IT WITH A TINY DROP OF GLUE TO HOLD IT IN PLACE. SAME FOR THE NUMBER PLATE BRACKET

THE PARTS CAN BE CAREFULLY REPOSITIONED SLIGHTLY IF NECESSARY.

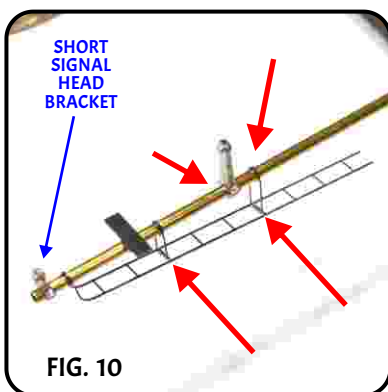

ONCE THIS INITIAL GLUEING HAS DRIED, ADD MORE GLUE TO EACH JOINT USING THE WIRE AND THE GLUE RESERVOIR (FIG. 10).

SLIDE THE SHORT SIGNAL HEAD BRACKET INTO PLACE AND GLUE IT IN PARALLEL WITH THE LONG BRACKET. APPLY THE NUMBER PLATE TO THE NUMBER PLATE BRACKET USING SUPER GLUE.

APPLY THE BASE ASSEMBLY AT "GROUND" LEVEL AND ADD THE POST CAP TO THE MAST. THESE PARTS CAN BE SUPER GLUED TO THE ASSEMBLY.

FINALLY, PRIME AND PAINT THE ASSEMBLY. WE RECOMMEND A LAQUER BASED PRIMER AND A SPRAY APPLICATION OF THE FINAL COAT OF PAINT.