

Parts Included

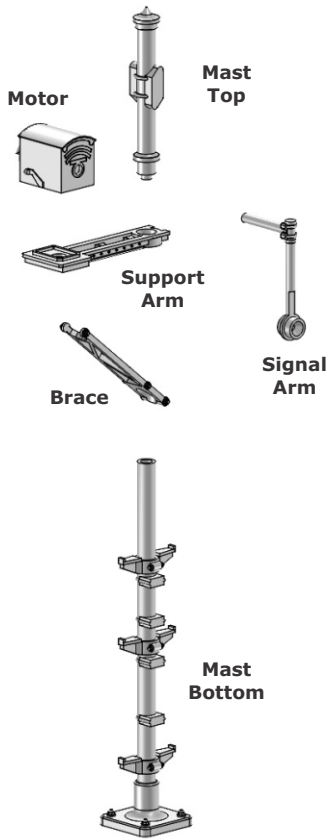

Tools You May Need:

- 1/32" Drill Bit
- Needle Files
- Dremel Tool
- CA (Super Glue)
- Flat-Nose Pliers

We recommend using Duro brand Super Glue to assemble the parts.

Optional Tools That May be Helpful:

Photo-Etch Bending Tool

(We recommend **The Small Shop** brand of tools and is available at Showcase Miniatures)

Clean and Deburr all Parts before beginning assembly.

Do Not Remove the Photo-Etch Parts from their fret yet - Painting Recommendations on back.

Before Applying Glue Test fit all parts.

Drill Opening In Motor
With 1/32" Drill Bit
(available on our website)

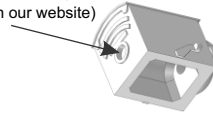

STEP 1



Stainless Steel Etch Parts **Not Used**

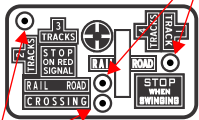

Not Used

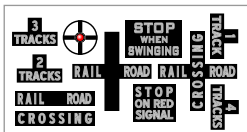
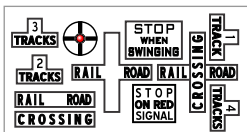
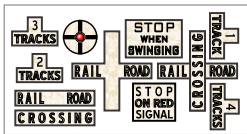

Printed Graphics

STEP 2

Drill Out with 1/32" Drill
(See Above)

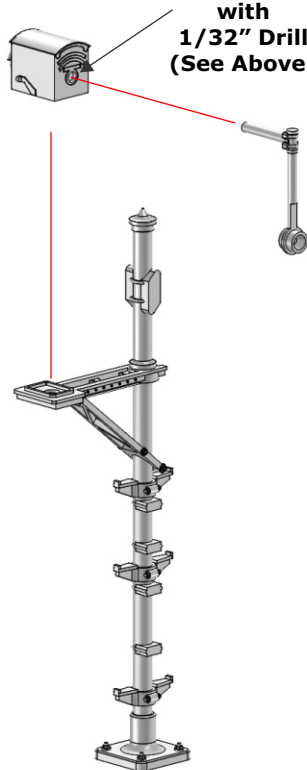

STEP 3

Attach Photo-Etch or Printed Graphics

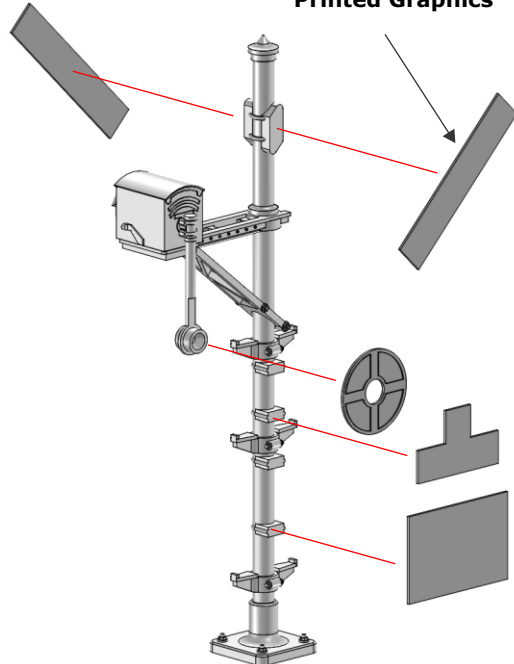

Painting / Finishing

Provided in the kit is a variety of options to finish the model.

Printed graphics (both weathered and un-weathered) are included. These can be cut out and attached with CA type super glue.

For finest detail, the photo-etched parts can be used. Below are the steps we used to get crisp black and white finish on signs and the wigwag target disk.

Paint the cavity of the wigwag target RED. After the paint has dried, fill the cavity with a gloss medium or Kristal Klear.

For Reflective silver Lettering on Black Background:

Paint the entire fret Flat Black and, once the paint has COMPLETELY dried, carefully scrape away the black paint to reveal the raised detail.

The Magnetic Wigwag Flagman Model 10

The Magnetic Wigwag Flagman is a standard wigwag type railroad highway crossing signal used to automatically indicate and warn highway traffic of the approach of a railroad train. A visual warning is presented in both directions by a horizontal swinging red light and disc, and an audible warning by the sound of a gong at each stroke of the wigwag banner.

The effective danger warning given by a swinging red light is universally understood and recognized as meaning STOP. The use of the wigwag signal with its swinging red light in wigwag banner disc for the one and only purpose of protecting highway crossings, provides an unmistakable warning that a railroad train is approaching.

The Magnetic Wigwag Flagman Model 10 provides an effective visual warning display including swinging movement of Wigwag Banner Disc and swinging display of Flashing Red Light indicating towards approaching highway traffic in both directions.

Standard location at near right hand side of highway as viewed by approaching highway traffic, with one signal at each side of railroad tracks

Reflector "STOP WHEN SWINGING" Sign and Non-Reflector Track Number Signs meeting standard requirements indicate in one direction only. Non-Reflector Cast Iron "RAILROAD CROSSING" Sign for two-way indication.

....The Magnetic Signal Co. Manual.

For Black Lettering on a White Background:

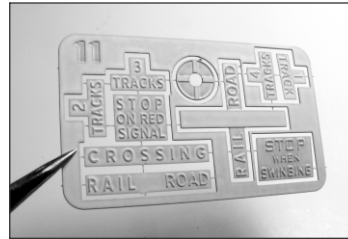

The entire Fret was spray painted **Flat White**.

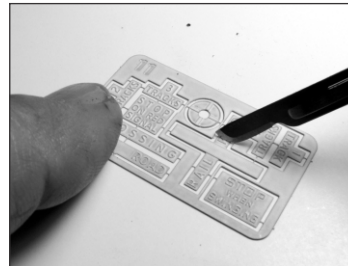

Once the paint is COMPLETELY Dry the paint on the raised detail was carefully scraped off the surface using a curved knife blade or 600 grit emery cloth (sand paper).

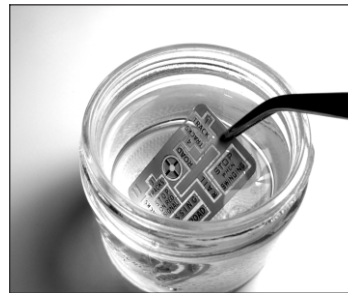
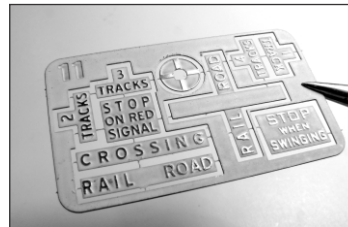

The Entire Fret was dipped into a solution of Black Oxide for Stainless Steel from EPI (Electrochemical Products Inc.)

www.epi.com

This sample size will last for many projects.

Directions from EPI were **closely** followed to achieve very satisfactory results. We used it at full strength.

The product number is **Insta-Blak SS-370 (not the gel)**

You will need to call them because the sample (which is \$20 at this time) is not listed in the drop down menu online but they can assist you by phone at 262-786-9330

